

GT
MOMENTUM™

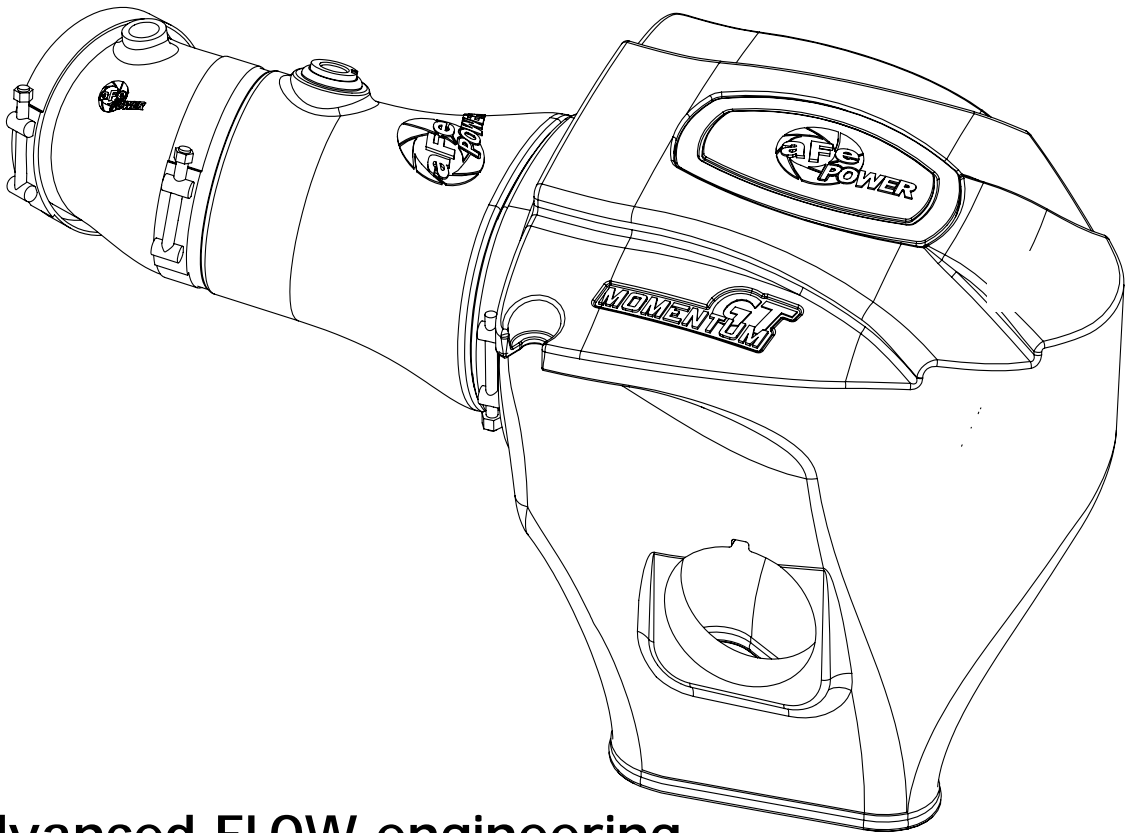

advanced FLOW engineering

Instruction Manual P/N: 52-72205 / 51-72205 / 54-72205

Make: **Dodge** Model: **Challenger SRT Hellcat** Year: **2017-2018** Engine: **V8-6.2L (sc) HEMI**
Make: **Dodge** Model: **Charger SRT Hellcat** Year: **2017-2018** Engine: **V8-6.2L (sc) HEMI**



- Please read the entire instruction manual before proceeding.
- Ensure all components listed are present.
- If you are missing any of the components, call customer support at 951-493-7100.
- Ensure you have all necessary tools before proceeding.
- Do not attempt to work on your vehicle when the engine is hot.
- Disconnect the negative battery terminal before proceeding.
- Retain factory parts for future use.

Label	Qty.	Description	Part Number
A1	1	Air Filter (Pro DRY S)	21-91101
A2	1	Air Filter (Pro 5R)	24-91101
B	1	Tube	05-72205B1
C	1	Housing	05-72201B2
D	1	Clamp, T-Bolt (4-7/16"-4-3/4")	03-50319
E	1	Clamp, T-Bolt (4-1/8"-4-1/2")	03-50262
F	1	Seal Trim 7/16" (21" in.)	05-00072
G	1	Coupling, Silicone	05-01352
H	1	Grommet, Rubber	03-50167
I	1	Fitting, Air Temp Sensor	05-01454

Tools needed: Tools needed: 8mm and 10mm nut driver or socket, flat screw driver, and T20 torx driver.

Note: Legal in California for use on race vehicles only. The use of this device on vehicles used on public streets or highways is strictly prohibited in California and others states that have adopted California emission regulations.

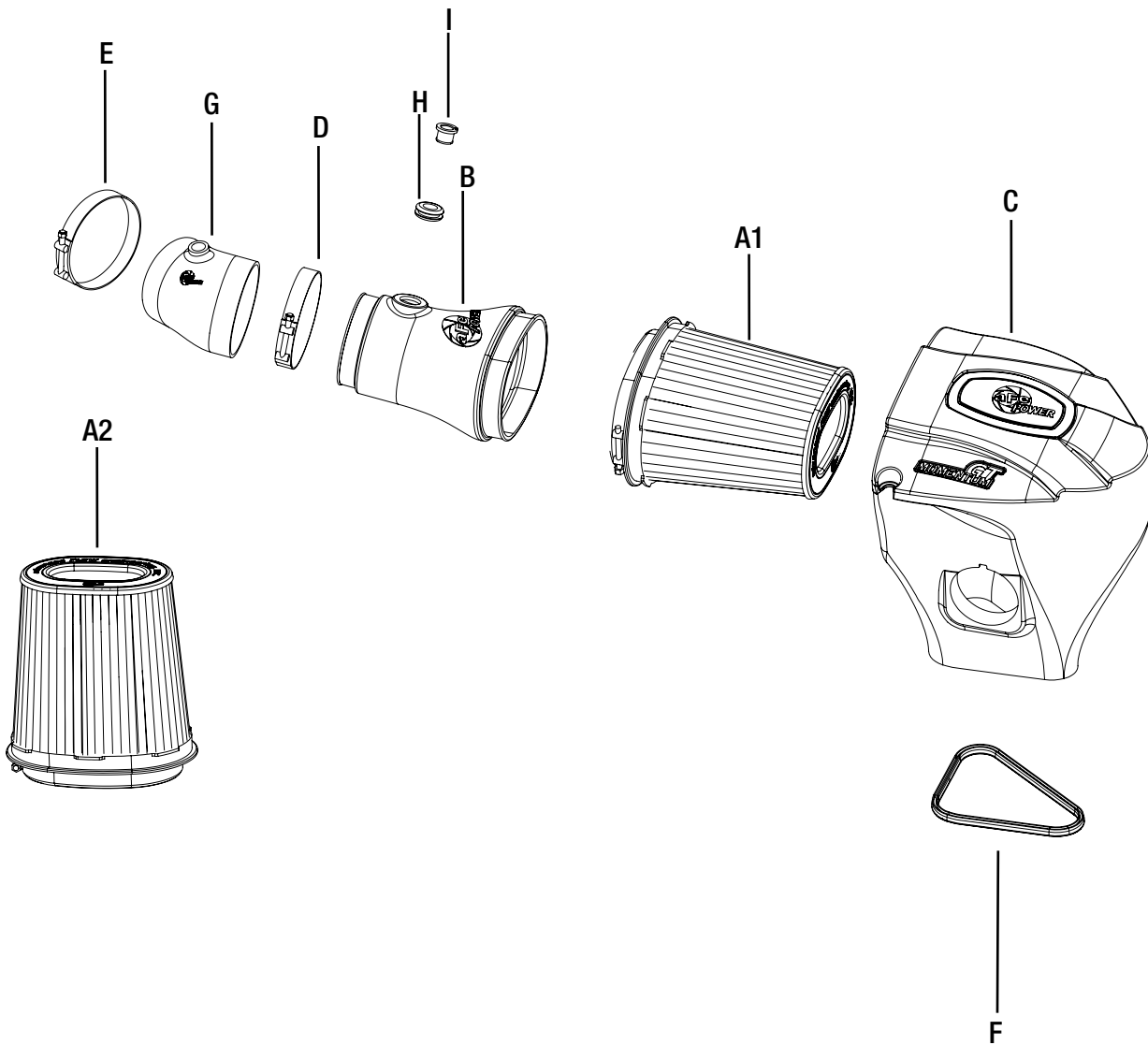



Refer to Figure A for Steps 1-4

- Step 1: Disconnect the Temperature sensor and breather fitting.
- Step 2: Remove bolt securing the housing.
- Step 3: Untighten clamp at the throttle body.
- Step 4: For Challenger vehicle, pull the housing assembly as one piece outside of the vehicle.

REMOVAL



Figure B

Refer to Figure B for Step 5

Step 5: For Charger, open the housing and remove the factory filter. Then disconnect the inlet duct and pull the bottom part of the housing outside of the vehicle. (The inlet duct is not removable)

**Figure C****Refer to Figure C for Steps 6-9**

Step 6: Transfer the grommet from the factory air box to the aFe housing.

Step 7: Install trim seal at the bottom edge of the aFe housing.

Step 8: Decide if you want to use the dry or oiled filters. Slide the selected filters inside the aFe housings until they lock in place. Install clamp on filter end but, do not tighten at this time.

Step 9: For Challenger vehicle only, transfer the inlet duct to the aFe housing.



Figure D

Refer to Figure D for Steps 10-11

Step 10: Make sure factory grommet is installed correctly into hole.

Step 11: Install aFe housing assembly into vehicle. For Charger only, re-connect factory inlet duct while installing the housing in.

**Figure E****Refer to Figure E for Step 12**

Step 12: Remove the temperature sensor from factory housing. Install the provided grommet into the hole on the aFe tube then press in the aluminum fitting. Secure the temperature sensor into the aluminum fitting by turning clockwise.



Figure F

Refer to Figure F for Step 13

Step 13: Install the coupling over the throttle body with the clamp. Do not tighten yet. Make sure it's oriented correctly.

**Figure G****Refer to Figure G for Steps 14-18**

Step 14: Install the aFe tube by sliding it first into the filter then into the coupling.

Step 15: Make sure everything is aligned correctly, then tighten all clamps.

Step 16: Reconnect the breather fitting by pushing it firmly into the coupling.

Step 17: Re-install the bolt removed at step 2 to secure the housing.

Step 18: Reconnect the temperature sensor. Your installation is now complete.

NOTE: Check all clamps and connectors after 200 miles.

PAGE LEFT BLANK INTENTIONALLY



PAGE LEFT BLANK INTENTIONALLY

PAGE LEFT BLANK INTENTIONALLY



Pro DRY S Air Filter



P/N: 21-91101

Pro 5R Air Filter



P/N: 24-91101

Pro DRY S Restore Kit



P/N: 90-59999

Blue Squeeze Restore Kit



P/N: 90-50501

Blue Aerosol Restore Kit



P/N: 90-50001

Cat-Back Exhaust System



P/N: 49-32053 (Challenger)

Exhaust Connection Pipes



P/N: 48-32015-YC (Street)
48-32015-YN (Race)

Long Tube Headers



P/N: 48-32014-YC (Street)
48-32014-YN (Race)

Sprint Booster V3



P/N: 77-12002

aFe Gloves



P/N: 49-10149

To purchase any of the items above, view airflow charts, dyno graphs, photos, and video; please go to aFepower.com.

Warranty

General Terms:

- aFe warrants their products to be free from manufacturer's defects due to workmanship and material.
- This warranty applies only to the original purchaser of the product and is nontransferable.
- Proof of purchase of the aFe product is required for all warranty claims.
- Warranty is valid provided aFe instructions for installation and/or cleaning were properly followed.
- Proper maintenance with regular inspections of product is required to insure warranty coverage.
- Damage due to improper installation, abuse, unauthorized repair or alteration is not warranted.
- Incidental or consequential damages or cost, including installation and removal of part, incurred due to failure of aFe product is not covered under this warranty.
- All warranty is limited to the repair and/or replacement of the aFe part. To request Return Goods Authorization ("RGA"), email RGA@afepower.com or call (951)493-7100. Upon receipt of the RGA, you must return the product to the address provided in the RGA, freight prepaid and accompanied with a dated proof of purchase and the RGA. Upon receipt of the defective product and upon verification of proof of purchase, aFe will either repair or replace the defective product within a reasonable time, not to exceed thirty days.

Product Category	P/N Prefix	Warranty duration
Direct OE Replacement Filters	10, 11, 30, 31, 71, 73	Life of the vehicle
Racing Filters	18	1 year
Universal	21, 24, 72	2 years
Air Intake Systems	50, 51, 54, 55, 75	2 years
Exhaust Systems	49	2 years
Intercoolers & Intercooler Tubes	46-2	2 years
Intake Manifolds	46-1	2 years
Differential Cover	46-7	Life of the vehicle
Exhaust Manifolds	46	2 years
Throttle Body Spacers	46-3	2 years
Fluid Filters	44	90 days
Pre-Filters	28	2 years
Heavy Duty OE Replacement	70	2 years
PowerSports OE Replacement	81, 87	2 years
PowerSports Intake Systems	85	2 years

No other warranty expressed or implied applies nor is any person or advanced FLOW engineering authorized to assume any other warranty. Some States do not allow the exclusion or limitation of incidental or consequential damages or do not allow limitations on how long an implied warranty lasts, so the above limitations or exclusions may not apply to you. This warranty gives you specific legal rights, and you may also have other rights which vary from State to State.



advanced FLOW engineering, inc.
252 Granite Street Corona, CA 92879
TEL: 951.493.7100 • TECH: 951.493.7134
E-Mail: Tech@aFepower.com